

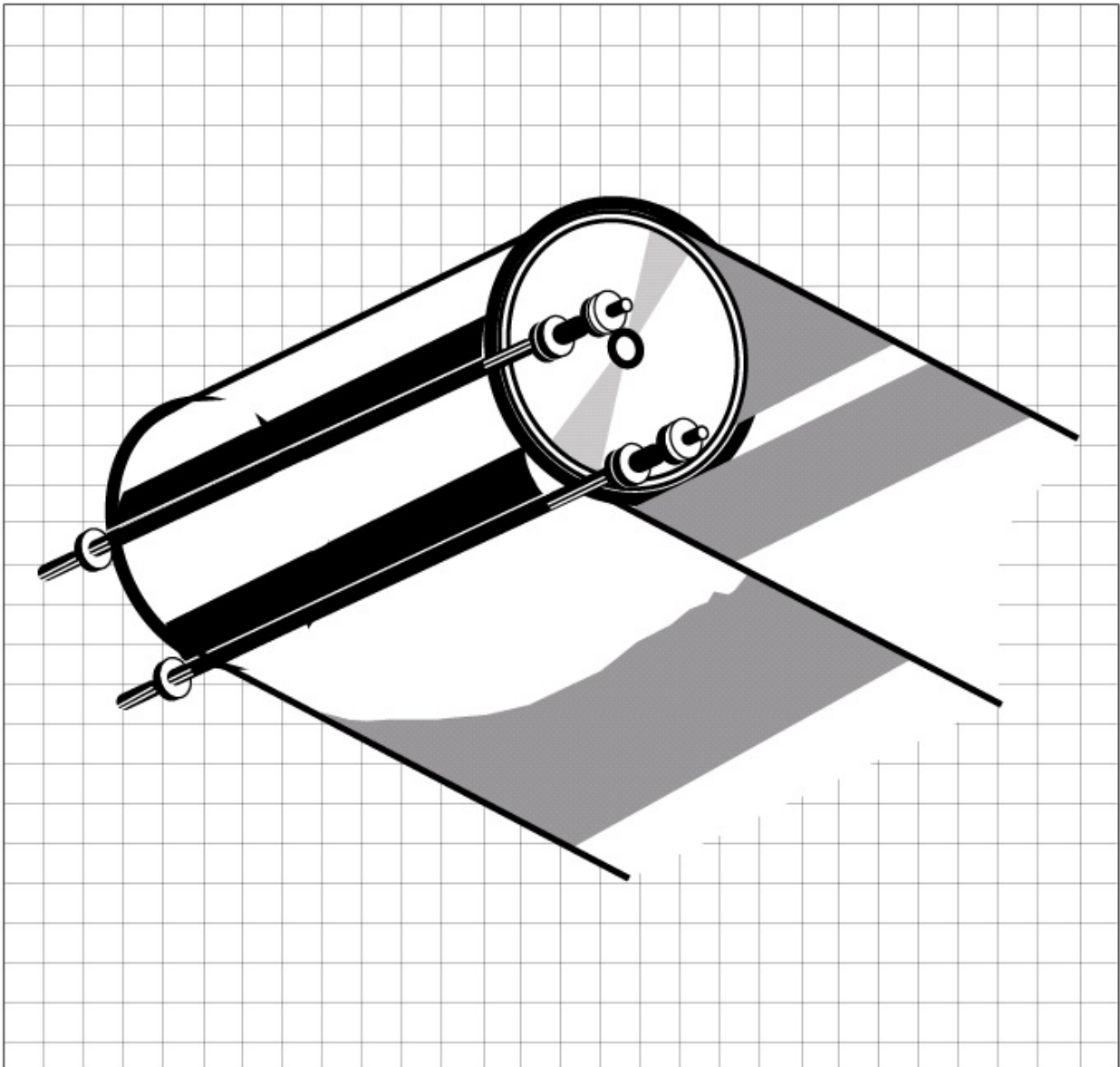

Conveyor Belt Maintenance



Conveyor belt maintenance not only includes proper care of the belt itself but also includes care and maintenance of the frame and accessories.

The first step in the process is to design an inspection form to encompass all aspects of each conveyor. This brochure is designed to assist in the actual design of the inspection report and the steps needed to correct any problems that you see when making this inspection.

This inspection form will take into account various types of conveyors from package handling to bulk haulage, therefore some of the items covered in our inspection and repair report may not apply to your particular conveyor.

Table of Contents

I. Belt Shut Down and Empty.....	3
II. Belt Running Empty.....	4
III. Belt Running Loaded.....	4
IV. Corrective Action.....	4
V. Inspection Form and Checklist.....	7 & 8

I. Belt Shut Down and Empty

The first step is to inspect the conveyor belt when the system is shut down and empty. This allows the opportunity to check for any damage to the belt or splice. The conveyor should be locked out while making this inspection.

Rubber belt damage should be repaired using the hot vulcanized repair method or the cold repair method. Belt fabrics that are exposed to the weather or to product contamination should be properly cleaned, dried, then covered with new rubber. These repairs are critical to prevent moisture from penetrating the belt and breaking down the cover adhesions, and to prevent product contamination from abrading the carcass and also breaking down the adhesions. Very few, if any repairs can be made to light-weight belts.

The splice can also be inspected and if damage in the splice is visible it is suggested that the splice be repaired or replaced.

This is also a good time to walk the conveyor and check the following components.

- A) Tail Pulley free from build-up and trapped material
- B) Tail Pulley damage
- C) Skirting in the loading area
- D) Impact Bed or Impact Idler damage

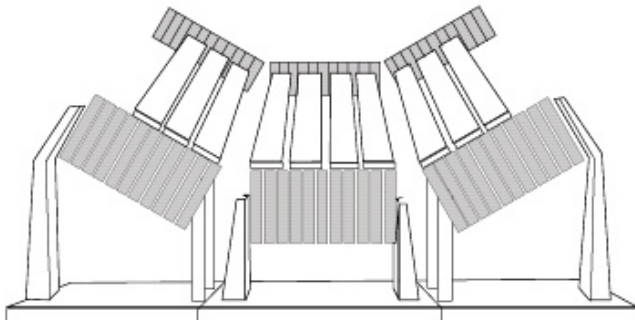

- E) Slider Bed clean and smooth
- F) Carrying Side Idler damage
- G) Carrying Side Self Trainers - operational and not tied off
- H) Secondary Loading Stations
 - a) Skirting
 - b) Impact Bed or Impact Idler damage
- I) Tripper Frame damage
- J) Tripper Discharge Pulley - clean
- K) Tripper Bend Pulleys - clean
- L) Head Pulley and/or Drive Pulley
 - a) Clean
 - b) Check for worn lagging
 - c) Re-lag Drive Pulley if rubber is old, worn, smooth and hard
- M) Head Pulley cleaner or scraper - operational
- N) Head Pulley Snub - clean
- O) Return Idlers - clean & turning freely
- P) Bend Pulleys - clean
- Q) Take-Up - clean
- R) Return Side Self Trainers - operational and not tied off
- S) Damage to return side frame due to mistraining
- T) Plow or Scraper in front of Tail Pulley - operational

The preceding list should be used as a guide when inspecting the conveyor while it is empty and shut down.

Numerous items in the preceding list contained the words clean or operational. Pulleys or idlers that have build up on them will cause tracking problems. The same can be said for pulleys that have some of the rubber lagging worn off.

Scrapers, plows and self-trainers must be operational to perform their tasks. Belt damage, pulley damage and tracking problems will result if these accessory pieces of hardware are not maintained.

II. Belt Running Empty

The conveyor should be turned on and run empty. The purpose of this is to walk the conveyor, while running empty, to check for any tracking problems. Before any adjustments are made to correct a tracking problem, the system will need to be inspected under running conditions when loaded, because empty belts and loaded belts do not necessarily track the same way.

III. Belt Running Loaded

The next step in our inspection process is to run the belt in a loaded condition. We will add a few new steps in the inspection process and repeat a few of the previous steps.

The following is our check list for operating the conveyor while loaded:

- A) Tail Pulley - Turning freely without bearing noise, product build up or carryback; belt tracking satisfactorily
- B) Load area spillage
- C) Carry Side Idlers - turning freely
- D) Carry Side Self-Trainers - functioning
- E) Secondary Loading Station spillage
- F) Tripper Area
 - a) Tracking

- b) Spillage
- G) Head Pulley and or Drive Pulley
 - a) Smoothly running
 - b) Slippage when starting or running
 - c) Belt Cleaners - functioning
 - d) Belt Tracking
- H) Head Pulley Snub - turning freely without bearing noise and clean
- I) Return Idlers - clean and turning freely
- J) Bend Pulleys - turning freely without bearing noise and clean
- K) Take-up Pulley - turning freely without bearing noise, clean, moving freely in the frame
- L) Return Side Self Trainers - functioning
- M) General Belt Tracking
- N) Plow or Scraper in front of Tail Pulley - functioning

IV. Corrective Action

The last step is to take the corrected action required on the conveyor in addition to:

- A) Clean Up
- B) Lubrication
- C) Safety Concerns - such as installing or repairing conveyor crossovers, safety stop cables, holdbacks on incline conveyors, edge limit switches, motor guards, hand rails, etc.

We have mentioned the word cleanliness throughout this brochure. Maintaining a clean system can not be stressed enough.

A conveyor system with carryback on the return side is the single biggest reason that conveyor

belts are replaced, return idlers and pulleys are replaced and structure is worn through. Material build up on the belt and hardware causes tracking problems, that will lead to edge damage, that leads to new belt and new idlers.

We urge you to use scrapers on the head pulley and plows in front of the tail pulley as prevention for damage in your maintenance planning.

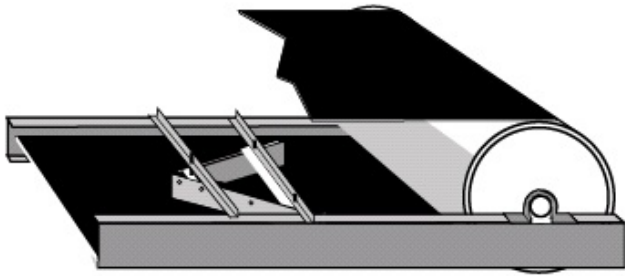

Some sticky materials present a real challenge when it comes to preventing carryback. We would like to offer a few additional suggestions as to handling these products.

Cleated belts may be reversed to allow better release at the discharge point.

A dual scraper system on the head pulley is the most common way to eliminate product carry-back.

A water spray on the belt cover along with wiper blades will effectively remove most products from sticking to the cover.

A series of out of round (cam shaped) return idlers will also assist in cleaning. These idlers are spiral wound from the edges towards the center of the idler and work on the premise of a turning beater bar arrangement.

A compressed air blast has been successfully used on material like coal and fine wet sand.

A power driven revolving brush will help remove

product from the belt. This method is rarely used because the bristles tend to clog up with material and wear out quickly. A brush may be the only solution for cleated belts.

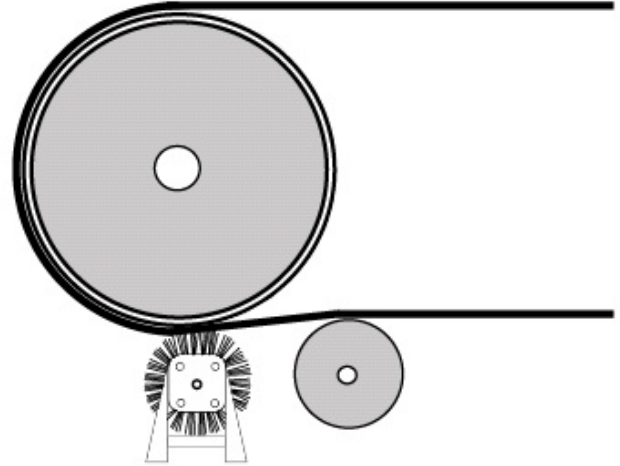

Product build up on return side pulleys is a major concern. If your belt is not effectively clean on the return run, then any bend pulleys or head snub pulley that come in contact with the carry side of the belt will accumulate product. We would like to offer a few hints on pulley and idler cleaning.

All return side pulleys that come in contact with the carry cover can be lagged with a soft rubber vulcanized to the pulley. The constant flexing action of the soft lagging will cause material to fall off and reduce material accumulation.

A lever weighted urethane scraper pressed against the pulley face, is an excellent way to remove build up. This system causes additional wear on the pulley face so it is suggested to use heavier walled return bend pulleys when using a scraper. If a scraper is applied to a head snub or bend pulleys at the take-up area then deflector plates will have to be installed to deflect the build up away from the belt.

Return idlers can be rubber covered and will help prevent product from sticking to the return idlers.

Return idlers can be purchased that are nothing more than discs mounted on a shaft. These discs can be made of soft rubber, urethane, or ceramics. This type of return idler can be very effective to prevent build up. The major problem when using this style of return roller is that the manufacturers do not put enough discs on the shaft to effectively support the belt in the middle, and support the edges of the belt if any mis-tracking occurs.

Another effective measure is called a turnover system. By the use of a series of rollers the belt is flipped over at the head and tail on the return side. This allows the belt to run the return side with the carry (dirty side) side up and the pulley (clean side) side down in contact with the return

rollers. Any spillage from the product carryback will be limited to the two twist areas. For more information on turnover systems, refer to our brochure on Conveyor Design Tips.

The following inspection form and checklist should be used as a guide for your conveyor systems. There may be additions or deletions depending on your particular conveyor designs.

CONVEYOR INSPECTION FORM AND CHECKLIST

Inspection Date _____

Conveyor Number _____

I. Belt Shut down and Empty

Corrective Action

- _____ Belt Condition
- _____ Splice Condition
- _____ Tail Pulley
- _____ Skirting
- _____ Impact Bed/Idlers
- _____ Slider Bed
- _____ Carry Side Idlers
- _____ Carry Side Self Trainers
- _____ Secondary Loading Station
- _____ Tripper Frame
- _____ Tripper Discharge Pulley
- _____ Tripper Bends
- _____ Head / Drive Pulley
- _____ Head Pulley Cleaner
- _____ Head / Drive Pulley Snub If Present
- _____ Return Run Drive
- _____ Return Idlers
- _____ Bend Pulleys
- _____ Take-Up Pulley
- _____ Return Side Self Trainers
- _____ Return Side Frame
- _____ Tail Pulley Plow / Scraper

II. Belt Running Empty

Corrective Action

_____ Tracking

III. Belt Running Loaded

_____ Tail Pulley

_____ Spillage in Load Area

_____ Carry Side Self trainers

_____ Secondary Load Station Spillage

_____ Tripper Area

_____ Tracking

_____ Spillage

_____ Head Pulley

_____ Drive Pulley

_____ Head Pulley Cleaner

_____ Head / Drive Pulley Cleaner

_____ Head / Drive Pulley Snub

_____ Return Idlers

_____ Bend Pulleys

_____ Take-Up Pulley

_____ Return Side Self Trainers

_____ Belt Tracking

_____ Tail Pulley Plow / Scraper

IV. Corrective Action

_____ Clean Up

_____ Lubrication

_____ Safety